

Boshco-DUSTEK

Woodworking Machinery and Dust Collection Systems



6K DUNHAM ROAD BILLERICA, MA 01821

P: 978-667-1911 F: 978-671-0011 e- mail: jboshco@boshco.com www.boshco-dustek.com

2024 Boshco-Dustek CATALOG

We Look Forward to Assisting You with all Your Woodworking, Panel Processing, Dust Collection and Supply Requirements

SAWSTOP ICS 10" Cabinet Saw
3HP 5HP 7.5HP 1PH or 3PH 36" or
52" Rip 10" Blade Left Tilt Arbor



TIMESAVERS 1300 Series 37" 1-Head
15HP 3PH or 1PH Digital Thickness
From \$467.00/Month Delivered Installed*



FINANCE
Low Rates
1 Payment
Down

DUSTEK E1000 Dust Collector
10HP 3-Bag 4000cfm 12" Dia. inlet
Unique 3-Leg Design **Special Price**



ALTENDORF F5 Edgebander
PC Screen Corner Round 5min HeatUp
From \$1,249.00/Mo. Delivered Installed*



ALTENDORF®
GROUP/AMERICA

*All Trade
Ins
Considered*

CANTEK DWM Drawer Clamp
10"H x 24"D x 36"- 42"W Capacity
From \$179.00/Month Delivered*



ANDERSON Spectrum M-48 CNC Router
4ftx8ft 10HP Router Tool Changer Drill
From \$1,839.00/Month Delivered Installed*



**NEED
SERVICE**
Call or
Email



2024 Boshco-Dustek CATALOG

SawStop Table Saws with Brake Cartridge to Prevent Accidents



SawStop Industrial Cabinet Saw
 3HP 1Ph 36" \$4,715.00 52" \$4,825.00
 5HP 1Ph 36" \$5,349.00 52" \$5,459.00
 5HP 3Ph 36" \$5,349.00 52" \$5,459.00

SawStop Professional Cabinet Saw
 1.75HP 1Ph 30" \$2,849.00 36" \$3,073.00
 52" \$3,166.00 3HP 1Ph 30" \$3,358.00
 36" \$3,582.00 52" \$3,675.00



**Assembly
and Delivery
Available**

SawStop Contractor's Saw
 1.75HP 1Ph 30" \$1,999.00
 36" \$2,257.00 52" \$2,350.00

SawStop Brake Cartridge
 For 10" Blade \$99.00
 For Dado Set \$119.00



**We Maintain
Large SawStop
Inventory**

10" Carbide Blade
 40-Tooth \$89.00 80-Tooth \$119.00

Sliding Table Options
 Large Sliding Table \$1,695.00
 Sliding Crosscut Table \$1,399.00



Boshco-DUSTEK

Woodworking Machinery and Dust Collection Systems



2024 Boshco-Dustek CATALOG

ALTENDORF®

GROUP AMERICA

Precision German Made Sliding Table Saws and Edgebanders to meet your needs

Altendorf F4 Edgebander
Pre-Mill Corner Round Buffing
15" PC Sreen 5 Min Heat Up
From \$1,215.49/Month Delivered Installed*



**Local
Technicians**

Altendorf K36 Edgebander
Pre Mill Corner Round Buffing
15" Touch Screen 2 Motor End Trim
From \$1,799.00/Month Delivered Installed*



Altendorf F45 Sliding Table Saw
9ft 10ft 12ft Table Sizes
3 Control Choices CNC Fence
From \$905.00/Month Delivered Installed*



**Machines
Arrive Fully
Tooled Up**

Altendorf HandGuard Sliding Saw
Instant Retracting Blade Dual Tilt
ELMO Control Motorized Scoring Adj
From \$1,339.00/Month Delivered/Installed*



Altendorf WA80 Sliding Table Saw
7.5HP 10ft Table Man or CNC Fence
From \$609.00/Month Delivered Installed*



Altendorf F25 Sliding Table Saw
7.5HP Manual Fence w/Digital
From \$384.00/Month Delivered Installed*



Boshco-DUSTEK

Woodworking Machinery and Dust Collection Systems



2024 Boshco-Dustek CATALOG



Full Line of Quality Woodworking Machines for all Shop Applications

Cantek JB21P 21 Spindel Line Borer
 2HP 1Phase 3 Phase 74" fence w/stops
From \$149.95/Month Delivered*



Cantek P630HV 24" Planer
 10HP 3PH Spiral Cutterhead
From \$339.00/Month Delivered*



Super
High
Quality

Cantek SS512CB Shaper
 7.5HP 3ph motor 1-1/4" Spindle
From \$195.00/Month Delivered*



Cantek J168LH 16" Jointer
 7.5HP 3Phase motor Spiral Cutterhead
From \$219.00/Month Delivered*



We
Service all
Cantek
Machines

Cantek JDT75 Automatic Dovetailer
 21,500 rpm spindle 3Phase 230Volts
From \$279.00/Month Delivered*



Cantek 303S Single Blade Ripsaw
 10HP motor 3.35" thickness
From \$292.00/Month Delivered*



Boshco-DUSTEK

Woodworking Machinery and Dust Collection Systems



2024 Boshco-Dustek CATALOG



Full Line of Quality Woodworking Machines for all Shop Applications

Cantek JEN-60 Drawer Notcher
 Notches and Drills 3phase 230v
From \$249.95/Month Delivered*



Cantek DC40 4-Roll Feeder
 1phase 115/230v 3phase 230v
From \$1,595.00* Plus Shipping



Usually
Ships
from
Stock

Cantek MX340 Automatic Edgebander
 High Freq Mtrs 2mm Scraper Buffing
From \$499.00/Mont Delivered Installed*



Cantek PCS18 Pneumatic Chop Saw
 10HP 18" Blade LH or RH
From \$149.00/Month Delivered*



Installation
& Training
Available
on all
Models

Cantek D405M-8 Sliding Table Saw
 8'6" Table 7.5HP 3phase or 5HP 1Phase
From \$279.00/Month Delivered*



Cantek D405ANC Sliding Table Saw
 10'6" Table CNC Fence 7.5HP 1HP
From \$320.00/Month Delivered Installed*



Boshco-DUSTEK

Woodworking Machinery and Dust Collection Systems

2024 Boshco-Dustek CATALOG

ANDERSON AMERICA
Anderson Group

FANUC

Full Line of CNC Machining Centers FAST RUGGED All with FANUC Control

Anderson SELEXX5'x12'CNCAutoFeed
12HP Router Tool Changer Drill
2 Becker Vac Pumps PC Control
From \$3,124.00/Mo. Delivered Installed*

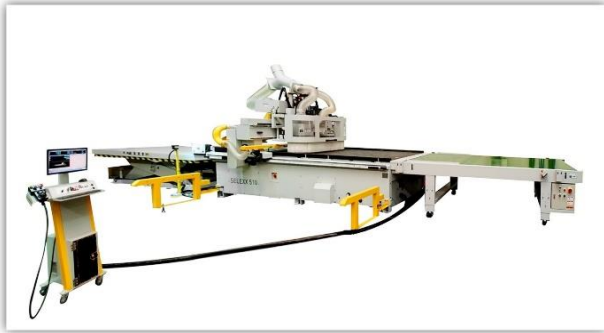

Anderson Stratos PRO 5ft x 10ft or 12ft
15HP On The Fly Tool Changer Drill
Available with Infeed/Outfeed Tables
Please Call For Delivered/Installed Pricing



Anderson EXXACT DUO Twin Table
20,000lbs 20" Z-Axis
Heavy Duty Routing Capacity
Please Call For Delivered/Installed Pricing



Anderson STRATOS Move 5-Axis
5' x 12' (to 24') Flat Table or Pods
Please Call For Delivered/Installed Pricing



FANUC PC Control
Available with Any of 6 Softwares



Extensive OnSite Training Included
Wood Aluminum Plastic Composites





2024 Boshco-Dustek CATALOG



Machines and Systems

New England's Exclusive Dealer for OMAL Precision Drill & Dowel Insertion Machinery

OMAL Velox 1300 Bore Glue & Dowel
Horizontal 51" Width One Dowel per Second
\$869.00/Month Delivered/Installed*



OMAL JollyColla Metering Glue System
1 Glue Tank 1 Water Tank On Wheels
Please call for Current Pricing*

OMAL HBD 1300 Bore Glue & Dowel
Available Vertical Router PC Control
Please call for Delivered Installed Price*





2024 Boshco-Dustek CATALOG

Casadei Buselatto Bonacin Special Machines

Bonacin NINA 2500 Case Clamp
Semi Auto Set Up 31"x45"x98"
From \$869.00/Mo. Delivered Installed*



Casadei FLEXA RM7 Edegebander
Pre-Mill 5mm Thickness Buffing
From \$779.00/Mo. Delivered Installed*



Casadei F205 Sliding Table Tilt Shaper
10HP 45° Tilt 1 1/4" Cross Cut Fence
From \$349.00/Month Delivered*



Busellato Jet Master T Compact Pt to Pt
43"x122" Router Drill Tool Changer
OnBoard Software Included
Please call for Delivered/Installed Pricing*



Boshco-DUSTEK

Woodworking Machinery and Dust Collection Systems

2024 Boshco-Dustek CATALOG



Wide Belt Sanders for Solid Wood, Veneered Panels, Knife Planing

Timesavers Speedsander Series 37" & 43"
10HP 3PH or 1PH Mobile Casters
From \$381.95/Mo. Delivered Installed*



Timesavers 13 Series 37" 2-Head
15HP & 10HP Digital Thickness
From \$646.00/Mo. Delivered & Installed*



Let's Discuss
Your Sanding
Requirements

Timesavers 23 Series 43" 2-Head
25HP & 20HP Digital Thickness
From \$1,146.00/Mo. Delivered & Installed*



Timesavers 52" 2-Head Planer/Sander
40HP & 25HP Spiral Cutterhead Combi
From \$1,329.00/Mo. Delivered Installed*



1 Man
Shop to
Large
Factory

Boshco-DUSTEK

Woodworking Machinery and Dust Collection Systems



2024 Boshco-Dustek CATALOG

Premier Machine Lines Represented by Boshco-Dustek in New England

Castle TSM-22 Pocket Screw Machine
Individual Router and Drill
\$4,999.00 Delivered*



Weima WL 6/30HP Scrap Grinder
31"x49" Hopper Carbide Cutterhead
\$From \$949.00/Month Delivered*



Schelling CNC Beam Saws
10ft Front Load up to Fully
Automatic Systems
Please Call for Quote



Mereen-Johnson Gang Ripsaw
Fixed or Shifting Blades Infeed Deck
Please Call for Quote



Razorgage Automatic Saw Measuring Systems
Stop or Pusher Style
Connect with Office Software
Please call for Quote

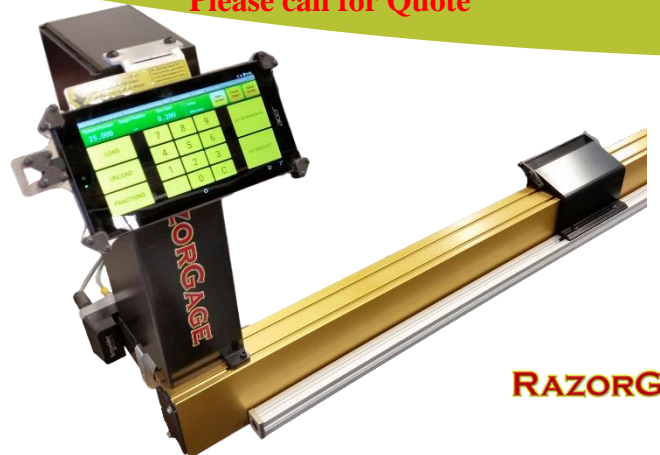

Leadermac Moulders
9"-12.5" width 5-9 Spindles
Please call for Quote



RAZORGAGE



2024 Boshco-Dustek CATALOG

PARTS SUPPLIES ACCESSORIES
Your Source for Everything to keep you Going

Jowat 286.80 Natural Glue Cartridges
Ships in 36 Cartridge Case
\$229.00ea



VSM Abrasives – Any Grit, Any Material
Any Size to meet your sanding requirements
We Stock 37”x 60” 43”x 60” 37”x 75”
Please call for Pricing



DORUS Edgebander Glue
Available in Cartridges and Pellets
\$419.95 Case Cartridges*



Parts and Accessories - Most Major Lines
Please Call Email for Pricing and Delivery
Please have your machine serial number



STEFF 2034 Power Feeder
3 Rollers 1Phase or 3Phase
From \$1,395.00 Delivered*



Replacement Feeder Wheels
Rubber Coated 2-Bolt Pattern
\$37.99ea





2024 Boshco-Dustek CATALOG

DUSTEK PARTS and SUPPLIES
Your Source for Everything to keep you Going

Dustek #01-010 Roll 50 Plastic Bags
\$157.00 per Roll + UPS
ALL Dustek Parts Ship Daily



Dustek Upper Cloth Filter Bags
48" \$99.00 60" \$124.00 72" \$134.00
96" \$159.00



Dustek 01-014 Quick Release Strap
24" Dia. for quick change plastic
\$49.00



Dustek 01-016 Clamp Type Strap
24" Dia. for upper cloth filter bags
\$39.00



Dustek Wall Mount Magnetic Starter
On/Off Buttons 3HP-25HP
Please call for Pricing



Dustek 01-044 Rubber Barrel Gasket
PSA One Side Fits Around 1-Barrel
\$20.50ea



Self-Contained Internal Return Dust Collection Systems 2024

Four series to choose from to meet your needs in both capacity and pricing!

ECONOMY

The Economy series is the newest member of the Dustek line. Very affordable and lighter weight to meet your needs. 3HP – 10HP



Model E1000

CLASSIC

The original Dustek Dust Collector. Proven Design, High Quality, Self-Contained, Internal Return Dust Collectors. 3HP – 20HP



Model C1000

DUSTY

Mobile High-Capacity, High Quality, Self-Contained, Single Phase, 3HP. Available with cloth or plastic collection bags.



Model JR-31

WHISPURR

Ultra Quiet, Self-Contained, Internal Return Dust Collectors, Dramatic Noise Reduction, Award-winning design, 7.5 – 25HP, “Why Roar when you can Whispurr”



Model W1500



2024 Boshco-Dustek CATALOG

DUSTEK Dust Collector Models and Specifications:

	Model	Horsepower	Inlet Diameter in Inches	Storage in Cubic Ft.	Filter Area in Sq. Ft.	Width/Height/Length in Inches	Distance of Inlet to Floor in Inches	Filtration & Collection Bags	Weight in Lbs.	Approximate Air Volume CFM	3 Phase	1 Phase
Dusty	JR-31	3	6	24	40	22x79x61	12	2	185	1,200		\$1,395.00
Economy	E300	3	6	15	25	24x113x46	71.5	1	500	1,200	\$3,995.00	\$4,095.00
	E500	5	10	30	50	24x113x73	72.5	2	800	2,000	\$4,795.00	\$4,895.00
	E750	7.5	12	45	100	24x125x97	75	3	850	3,000	\$5,595.00	\$5,695.00
	E1000	10	12	45	100	24x125x97	75	3	900	4,000	\$5,795.00	
Classic	C300	3	7	15	25	24x113x46	71.5	1	600	1,200	\$4,495.00	\$4,595.00
	C500	5	10	30	50	24x113x73	72.5	2	900	2,000	\$5,595.00	\$5,695.00
	C750	7.5	12	45	100	24x125x97	75	3	950	3,000	\$6,295.00	\$6,495.00
	C1000	10	12	45	100	24x125x97	75	3	1000	4,000	\$6,695.00	
	C1500	15	14	60	132	32x137x130	83	4	1250	5,000	\$9,395.00	
	C2000	20	14	60	210	32x173x130	83	4	1350	7,000	\$9,795.00	
Whispurr	W750	7.5	12	45	100	38x125x117	76	3	1150	3,000	\$12,095.00	\$12,295.00
	W1000	10	12	45	100	38x125x117	76	3	1350	4,000	\$12,295.00	
	W1500	15	14	60	132	42x137x149	81	4	1600	5,000	\$16,395.00	
	W2000	20	14	60	210	42x173x149	81	4	1800	7,000	\$16,995.00	
	W2500	25	16	75	260	42x173x173	81	5	2000	8,500	\$20,495.00	

Leasing and Financing Available.

Each Dustek self-contained dust collection system is supplied with :

- Cloth Filter Bags • Clear Plastic Collection Bags • Quick Release Straps for collection bags
- Clamp Type Straps for filter bags • Magnetic Clips • Operation Manual

All Classic and Whispurr models connected for 3-phase, 208-230/460 volt, 60 Hz (1-phase special order only)

All Economy models connected for 3-phase 230/460 volt, 60 Hz (1-phase special order only)

Dusty model JR-31 is 1-phase 230v only

Need more filter area? Any model can be retrofitted with taller filter bags

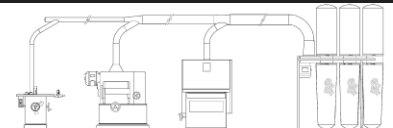

Diagram of DUSTEK Model C750 dust collector installation connected to a 10" tilting arbor saw table, a 24" single surface planer, and a 36" conveyor feed wide belt sander.



2024 Boshco-Dustek CATALOG

DUSTEK Dust Collector Parts, Supplies & Accessories:

Collection Bags

Plastic Collection Bags – 6mil (roll of 50)	157.00	01-010
Individual Plastic Collection Bag	3.95	01-012

Filter Bags

Filter bag models 300/500 48"	99.00	01-018
Filter bag models 750/1000/1500 60"	124.00	01-020
Filter bag Upgraded 750/1000/1500 72"	134.00	01-020U
Filter bag models 2000/2500 96"	159.00	01-022
Custom sizes and different materials available – call for pricing		

Straps

Quick-release	49.00	01-014
Clamp-type	39.00	01-016

Replacement Rods

Models 300/500 48" (price per set)	75.00	01-058A
Models 750/1000/1500 60" (price per set)	80.00	01-058B
Models Upgraded 750/1000/1500 (set) 72"	85.00	01-058U
Models 2000-2500 96" (price per set)	90.00	01-058C

Miscellaneous

Rubber barrel gasket	20.50	01-044
Shaft gasket (donut)	10.50	01-046
Magnetic clip	3.00	01-032

Teflon-Coated Filter Bags (for fine dust applications)

Teflon-coated 60" filter bag	185.00	01-034
Teflon-coated 72" filter bag	195.00	01-035
Teflon-coated 96" filter bag	215.00	01-036

Model JR-31 Dusty Junior Parts, Supplies & Accessories

Package of (10) plastic collection bags	29.95	01-052
Box of (100) plastic collection bags	269.55	01-053
Motor 3HP single phase	449.00	01-056
Magnetic control with push button	329.00	01-025
Fabric filter bag	64.00	01-050A
Re-usable fabric collection bag	64.00	01-050B
Quick-release strap	34.00	01-050
Impeller	299.00	01-042

Economy Motors

Model E300	3-phase 595.00	01-027A	1-phase 699.00	01-027B
Model E500	3-phase 635.00	01-027C	1-phase 755.00	01-027D
Model E750	3-phase 795.00	01-027E	1-phase 1100.00	01-027F
Model E1000	3-phase 945.00	01-027G		

Classic Motors

Model C300	3-phase 655.00	01-026A	1-phase 740.00	01-026B
Model C500	3-phase 765.00	01-026C	1-phase 855.00	01-026D
Model C750	3-phase 920.00	01-026E	1-phase 1265.00	01-026F
Model C1000	3-phase 1070.00	01-026G		
Model C1500	3-phase 1430.00	01-026H		
Model C2000	3-phase 1835.00	01-026I		

Whispurr Motors

Model W750			1-phase 1090.00	01-026J
Model W1000	3-phase 1025.00	01-026K		
Model W1500	3-phase 1445.00	01-026L		
Model W2000	3-phase 1745.00	01-026M		
Model W2500	3-phase 2090.00	01-026N		

Classic & Economy Impellers

Model C300	687.00	01-038A	Model W750	1225.00	01-040A
Model C500	699.00	01-038B	Model W1000	1350.00	01-040B
Model C750	725.00	01-038C	Model W1500	1545.00	01-040C
Model C1000	779.00	01-038D	Model W2000	1755.00	01-040D
Model C1500	875.00	01-038E	Model W2500	1899.00	01-040E

Whispurr Impellers

Magnetic Controls with Push Button

Model 300	3-phase 270.00	01-024A	1-phase 285.00	01-024B
Model 500	3-phase 280.00	01-024C	1-phase 290.00	01-024D
Model 750	3-phase 310.00	01-024E	1-phase 330.00	01-024F
Model 1000	3-phase 385.00	01-024G		
Model 1500	3-phase 470.00	01-024H		

Boshco-DUSTEK

Woodworking Machinery and Dust Collection Systems



2024 Boshco-Dustek CATALOG

SERVICES Offered By Boshco-Dustek

***Delivery by Boshco-Dustek Truck included within 100 Miles of Billerica MA
 Rigging (if Required) may be additional Installation by Boshco-Dustek Tech
 Financing Quotes are for 60 or 72 Months; 1 payment Down.**

Field Repair Service
 We Can Repair your Down Machines
Please call to Schedule



Dustek Custom Size Cloth Filter Bags
 We Have Special Bags Made Regularly
Please call for Quote



Custom Duct Work Design/Install
 Let Us Design & Install Your System
Please call for Quote

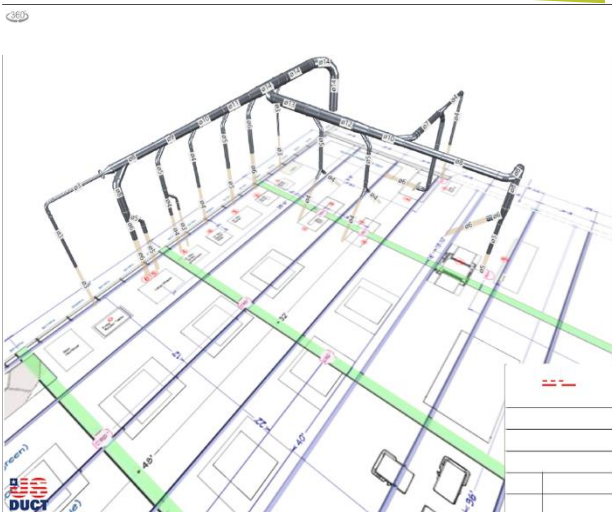

U S Duct Snap Together Duct Work
 We sell All Needed Parts to connect
 your shop machines to a Dustek
Please call for Quote

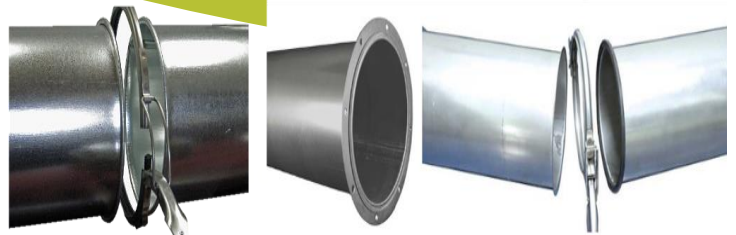

Appraisal Services
 We Offer All Types of Onsite Equipment
 Appraisals Fair market Auction Etc.
Please call for Quote



Equipment Financing

**We Work Closely with Our Customers
 Throughout the Financing Process**

- \$10,000 (\$200.63/month)**
 - \$25,000 (\$501.58/month)**
 - \$50,000 (\$1,003.15/month)**
 - \$100,000 (\$2,006.30/month)**
- 60 Months, 1 Payment Down**

Please call for Application

